



FULL LIFT SAFETYVALVE zARMAK



Body material	Nominal pressure	Nominal diameter	Max. temperature	Ex. index
A Grey cast iron	C 16 bar	DN 20-150	200°C	5701
F Cast steel	E 40 bar	DN 20-150	400°C	5702
R Cast stainless steel	E 40 bar	DN 20-100	300°C	5702CrNi

CE 0343

FEATURES

- flanges dimension according to PN EN1092
- valves made according to PN ENISO4126-1
- high tightness

APPLICATION *

* not all of the applications are suitable for all of the executions

media



STEAM



COM PRESSEDAIR



NEUTRAL FLUIDS

Data given can be changed without notice.

Edition 01/ 2018

ZETKAMA Sp. z o.o.
Ul. 3 Maja 12
PL 57-410 Ścinawka Średnia

Tel. +48 74 8652 193
Tel. +48 74 8652 111
Fax +48 74 8652 199

E-mail export@zetkama.com.pl
www.zetkama.com

FIG.570



MATERIALS, DIMENSIONS

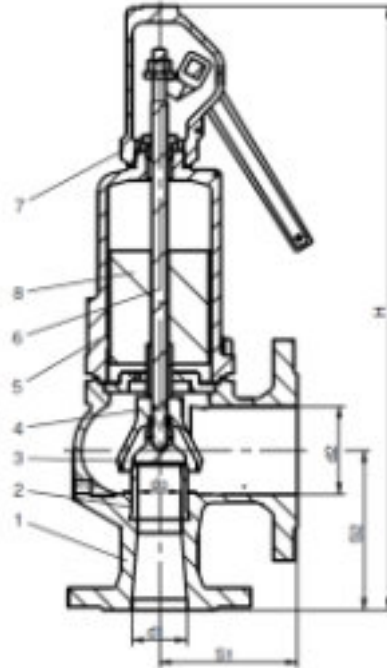

	Body material	A	F	R
	Type	standard	standard	standard
		01-1	01-1	
1	Body	EN-GJL-250 5.1301	GP240GH 1.0619	GX5CrNi19-10 1.4308
2	Seat	X39CrMo17-1 1.4122		X6CrNiTi18-10 1.4541
3	Disc	X39CrMo17-1 1.4122		X6CrNiTi18-10 1.4541
4	Bell	EN-GJS-400-15 5.3106		X6CrNiTi18-10 1.4541
5	Bonnet	EN-GJL-250 / EN-GJS-400-15 5.1301 / 5.3106	EN-GJS-400-15 / GP240GH 5.3106 / 1.0619	GX5CrNi19-10 1.4308
6	Spindle	X20Cr13 1.4021		X6CrNiTi18-10 1.4541
7	Lifting cap	EN-GJL-250 / EN-GJS-400-15 5.1301 / 5.3106	EN-GJS-400-15 5.3106	GX5CrNi19-10 1.4308
8	Weight	Steel		X6CrNiTi18-10 1.4541
Temperature range		-10...200°C	-40...400°C	-196...300°C

Data given can be changed without notice.

Edition 01/ 2018

ZETKAMA Sp. z o.o.
Ul. 3 Maja 12
PL57-410 Ścinawa Średnia

Tel. +48 74 8652 193
Tel. +48 74 8652 111
Fax +48 74 8652 199

E-mail export@zetkama.com.pl
www.zetkama.com

FIG.570



Body material		Type	A (PN16) F, R (PN40)								
DN	20x32		25x40	32x50	40x65	50x80	65x100	80x125	100x150	125x200	150x250
d _o (mm)		16	20	25	32	40	50	63	77	93	110
A (mm ?)		201	314	491	804	1257	1964	3117	4657	6793	9503
S ₁ (mm)		85	95	100	115	125	140	155	175	215	225
S ₂ (mm)		95	105	110	130	145	150	170	180	220	245
H (mm)		345	395	420	495	550	660	710	810	860	990
Pressure at the beginning of the opening (bar)	min	0,1*									
	max	0,7*									
Weight (kg)**		9,0	11,0	16,0	25,0	35,0	47,0	65,0	95,0	130,0	175,0

* For the body material R, diameters from DN20x32 to 100x150

** Total weight depends on the set pressure (weight weight)

DISCHARGE COEFFICIENTS PN16 and PN40

Media	Ranges	DN									
		20x32	25x40	32x50	40x65	50x80	65x100	80x125	100x150	125x200	150x250
Body material: A, F, R Standard type: (01-1) Nominal pressure: PN16, PN40											
S/G	b ₁ = 0,1 bar	0,50						0,46			

DIMENSIONS OF SUPPORTED LUG PN40

Drill of supported lug only onto client's request

DN	Body material: F, R All types Nominal pressure: PN40						
	A	B	C	L	E	d	s
	mm						
40x65	180	84	134	65	155	14	10
50x80	210	93	160	70	180	14	12
65x100	245	94	196	70	215	14	12
80x125	300	100	240	90	270	18	15
100x150	320	160	280	130	285	18	15
125x200	365	120	300	90	330	18	15
150x250	415	150	360	120	380	18	15

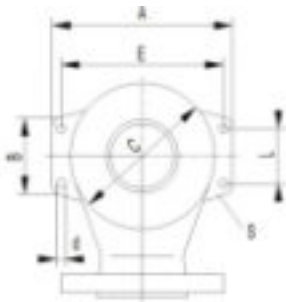

Data given can be changed without notice.

Edition 01/ 2018

ZETKAMA Sp. z o.o.
Ul. 3 Maja 12
PL 57-410 Ścinawa Średnia

Tel. +48 74 8652 193
Tel. +48 74 8652 111
Fax +48 74 8652 199

E-mail export@zetkama.com.pl
www.zetkama.com



CAPACITY TABLE FOR AIR

DNxDN PN16, PN40	20x32	25x40	32x50	40x65	50x80	65x100	80x125	100x150	125x200	150x250
A - flight computational area [mm ²]	201	314	491	804	1 257	1 964	3 117	4 657	6 793	9 503
Pressure at the beginning of bar opening (g)	Air 20°C [kg/ h]									
0,10	78,3	122	191	313	490	765	1 215	1 670	2 435	3 407
0,15	87,4	137	214	350	547	854	1 356	1 863	2 718	3 803
0,20	95,6	149	234	382	598	934	1 482	2 038	2 972	4 158
0,25	103	161	252	412	645	1 007	1 598	2 197	3 205	4 483
0,30	110	172	269	440	688	1 075	1 706	2 345	3 420	4 785
0,35	116	182	285	466	728	1 138	1 806	2 483	3 621	5 066
0,40	123	191	299	490	766	1 198	1 901	2 612	3 811	5 331
0,45	128	200	313	513	803	1 254	1 990	2 735	3 990	5 582
0,50	134	209	327	535	837	1 307	2 075	2 852	4 160	5 820
0,55	139	217	340	556	870	1 359	2 156	2 964	4 323	6 048
0,60	144	225	352	576	901	1 408	2 234	3 070	4 479	6 266
0,65	149	233	364	595	931	1 455	2 308	3 173	4 628	6 475
0,70	153	240	375	614	960	1 500	2 380	3 272	4 772	6 676

CAPACITY TABLE FOR SATURATED STEAM

DNxDN PN16, PN40	20x32	25x40	32x50	40x65	50x80	65x100	80x125	100x150	125x200	150x250
A - flight computational area [mm ²]	201	314	491	804	1 257	1 964	3 117	4 657	6 793	9 503
Pressure at the beginning of bar opening (g)	Saturated steam [kg/ h]									
0,10	51,8	80,9	126	207	324	506	803	1 104	1 610	2 252
0,15	57,1	89,2	139	228	357	558	885	1 217	1 775	2 483
0,20	61,8	96,5	151	247	386	603	958	1 316	1 920	2 686
0,25	66,0	103	161	264	413	645	1 023	1 406	2 051	2 869
0,30	69,8	109	171	279	437	682	1 083	1 488	2 171	3 037
0,35	73,4	115	179	294	459	717	1 139	1 565	2 283	3 194
0,40	76,8	120	188	307	480	751	1 191	1 638	2 389	3 342
0,45	80,1	125	196	320	501	782	1 242	1 707	2 490	3 483
0,50	83,2	130	203	333	520	813	1 291	1 774	2 588	3 620
0,55	86,3	135	211	345	540	843	1 338	1 839	2 683	3 753
0,60	89,3	140	218	357	559	873	1 385	1 904	2 777	3 885
0,65	92,3	144	226	369	577	902	1 432	1 968	2 871	4 016
0,70	95,4	149	233	382	597	932	1 480	2 034	2 967	4 151

Capacity calculated at overpressure $b_1 = 0,1$ bar

Data given can be changed without notice.

Edition 01/ 2018

ZETKAMA Sp. z o.o.
Ul. 3 Maja 12
PL 57-410 Ścinawa Średnia

Tel. +48 74 8652 193
Tel. +48 74 8652 111
Fax +48 74 8652 199

E-mail export@zetkama.com.pl
www.zetkama.com



OPTIONS



Type with inductive sensor with operation alert

Operation range:
depending on the type and diameter of the valve
Supply voltage:
10 ÷ 30 V [DC]
Degree of protection:
IP67, IP68 (depending on sensor type)
Operating temperature:
-25 ÷ 70°C
Other upon agreement with the manufacturer
Standard cable length
2000 mm



The product meets the requirements of the following standards

PN-EN 1127-1:2011
PN-EN 13463-1:2011
PN-EN 13463-1:2010

The product is labelled:



Standard flanges valves are drilled according to standards

PN-EN 1092-1 cast steel
PN-EN 1092-2 cast iron

Upon client's request, it is possible to make flange drillings according to ANSI standards or according to European standards other than basic ones (after consultation with the manufacturer)

ATTENTION

- In the case of when condensate forms, provide drainage in the lowest spot of blow-out installation. Drainage in the body valve is made only upon request of the customer.
- The valve should be mounted in vertical position.

Data given can be changed without notice.

Edition 01/ 2018

ZETKAMA Sp. z o.o.
Ul. 3 Maja 12
PL 57-410 Ścinawa Średnia

Tel. +48 74 8652 193
Tel. +48 74 8652 111
Fax +48 74 8652 199

E-mail export@zetkama.com.pl
www.zetkama.com

FIG.570



TYPES

Figure	Body material	Nominal diameter	Nominal pressure	Type
570	A Grey cast iron EN-GJL-250	20-150 mm	C 16 bar	01-1 normal type for gasesand vapours; sealing metal/metal
570	F Cast steel GP240GH	20-150 mm	E 40 bar	01-1 normal type for gasesand vapours; sealing metal/metal
570	R Cast stainless steel GX5CrNi19-10	20-100 mm	E 40 bar	01-1 normal type for gasesand vapours; sealing metal/metal

ORDERING

Figure	Body material	Nominal diameter	Nominal pressure	Type
570	A Grey cast iron EN-GJL-250	20-150 mm	C 16 bar	01-1 normal type for gasesand vapours; sealing metal/metal

Order example by index

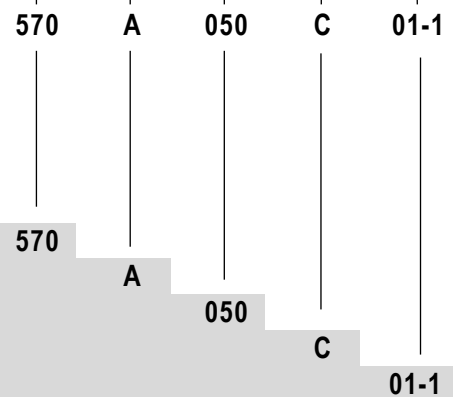

570 Full lift safety valve, flanged ends, angle form
 A Grey cast iron EN-GJL-250
 050 Nominal diameter (mm)
 C Nominal pressure PN 16
 01-1 Normal type for gasesand vapours; sealing metal/metal

Data given can be changed without notice.

Edition 01/ 2018

ZETKAMA Sp. z o.o.
 Ul. 3 Maja 12
 PL57-410 Ścinawa Średnia

Tel. +48 74 8652 193
 Tel. +48 74 8652 111
 Fax +48 74 8652 199

E-mail export@zetkama.com.pl
www.zetkama.com